

**RoHS COMPLIANT**

DESCRIPTION CONTROL			
REV	DESC	DATE	APP
A	FIRST RELEASE	2013/04/10	
B	CHANGE P/N	2013/04/25	
C	CHANGE CARTON SPEC	2013/04/29	
D	CHANGE DRAWING	2013/05/03	
D-1	CHANGE DRAWING	2013/05/07	
E	CHANGE DRAWING	2013/06/25	

HOUSING 6P

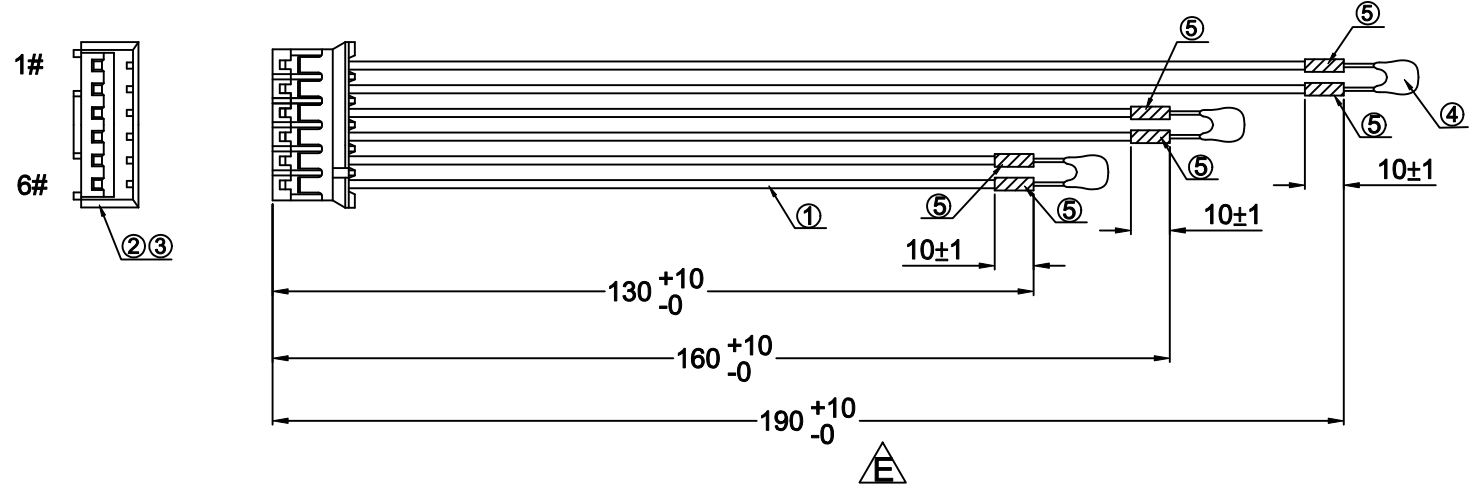

THERMISTOR

**NOTES:**

- PIN ASSIGNMENT SEE TO WIRE LIST.
- ELECTRICAL TEST CONDITION:
  - 100 %OPEN,SHORT & MISWIRE TEST,
  - INSULATOR RESISTANCE:20 Mohm MIN DC 300V 0.01sec..
  - CONTACT RESISTANCE:1ohm MAX.
  - EACH INDIVIDUAL SHRINK SLEEVE.10MM HAS BEEN MENTIONED.

ITEM	QTY	PART NUMBER	DESCRIPTION
5	6		BLACK HEAT SHRINK TUBE.
4	3		THERMISTOR NJ28NA0103H.
3	1		HOUSING:PITCH2.0MM 6PIN PHR-6.
2	6		TERMINAL:PITCH2.0MM.
1	6		UL1007 24AWG BLACK JUMP WIRE .

UNIT	mm	Projection			Seconn International Enterprise Co., Ltd.		
DRAWN	<i>Huang shenggen</i>	SCALE	1:1	TITLE			
CHECK, BY		REV	E	HOUSING 6PIN TO THERMISTOR			
APP, BY		DATE	2013/04/10	TOLERANCES			
DWG NO.	SE-S-0074-1			X.= ±	.X= ±	.XX= ±	.XXX= ±
PART NO.	0411-000-004		SHEET	1/2	SIZE	A4	

**RoHS COMPLIANT**

DESCRIPTION CONTROL			
REV	DESC	DATE	APP
A	FIRST RELEASE	2013/04/10	
B	CHANGE P/N	2013/04/25	
C	CHANGE CARTON SPEC	2013/04/29	
D	CHANGE DRAWING	2013/05/03	
D-1	CHANGE DRAWING	2013/05/07	
E	CHANGE DRAWING	2013/06/25	

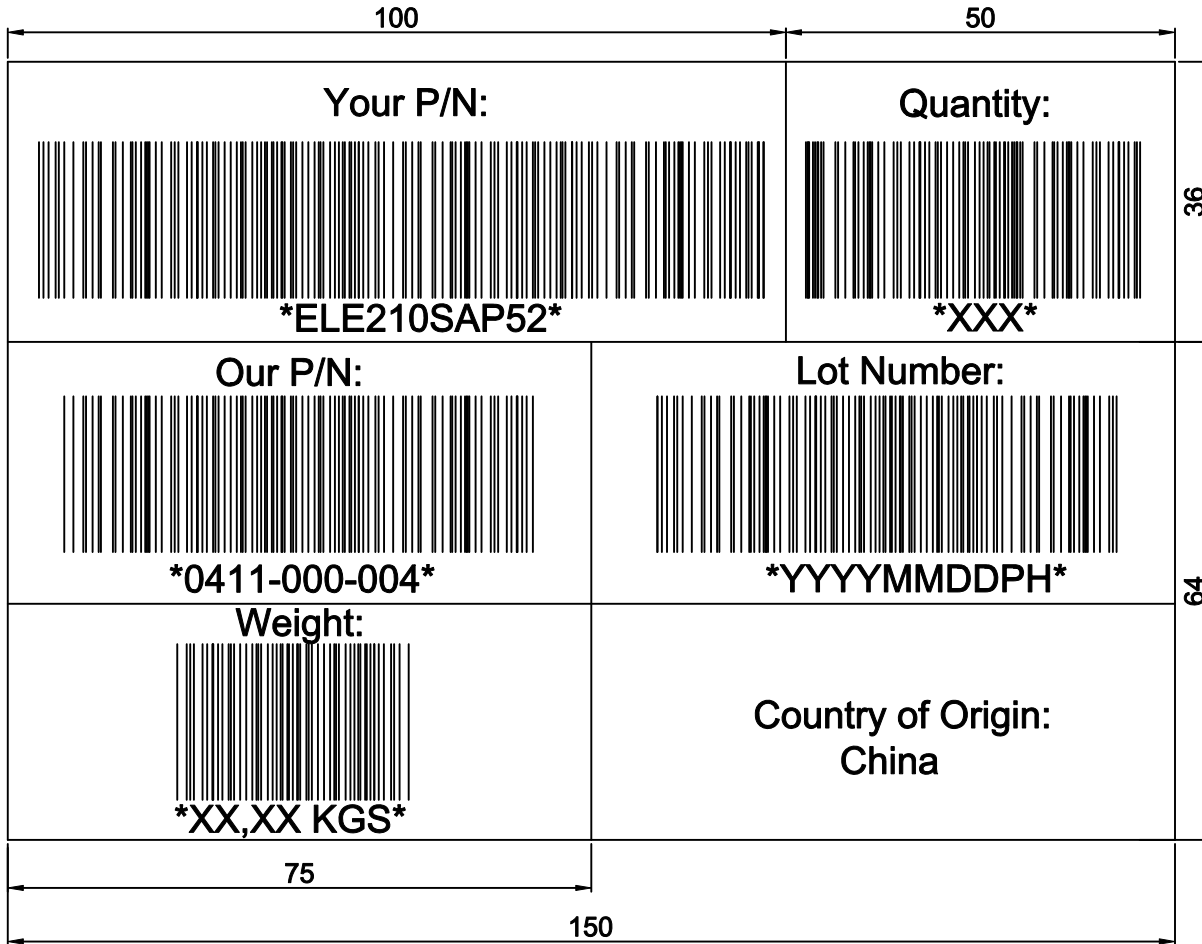

**CARTON LABEL**

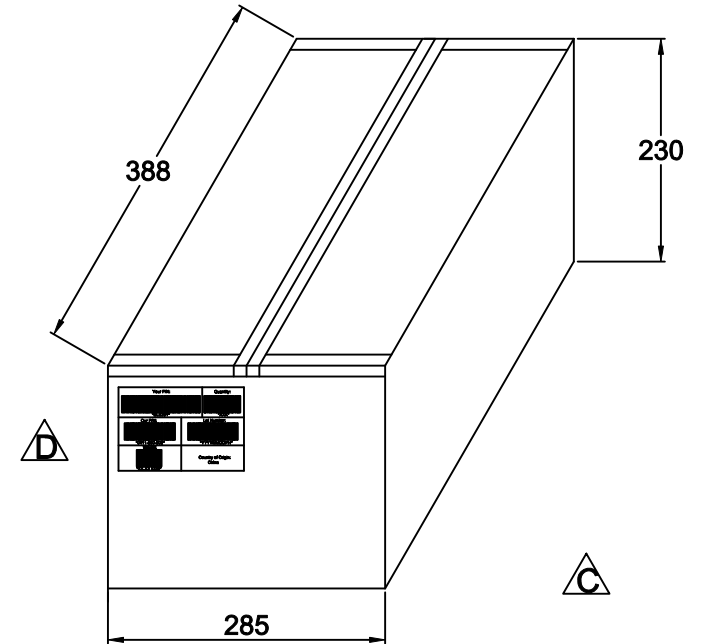

**CARTON**

Font type:Ariel 5mm  
Barcode type:code 3 of 9  
Barcode size:20mm  
(Except"Weight"10mm)

Lot number:YYYYMMDDH  
YYYY=year  
MM=month  
DD=day  
P=product with this production date,  
First P/N="A",next P/N=B,etc.\*  
H:Lot size,First 10K="A",next 10K="B",  
etc of this P/N.

UNIT	mm	Projection			Seconn International Enterprise Co., Ltd.
DRAWN	<i>Huang shenggen</i>	SCALE	1:1	TITLE	
CHECK, BY		REV	E	HOUSING 6PIN TO THERMISTOR	
APP, BY		DATE	2013/04/25	TOLERANCES	
DWG NO.	SE-S-0074-1	X.= ±	.X= ±	.XX= ±	.XXX= ±
PART NO.	0411-000-004	SHEET	2/2	SIZE	A4